

MINIMAT-ED Digital Electric Screwdriver

Straight handle design: torque ranges between 0.24 - 4.8 Nm

- flexible
- economical
- comfortable
- process reliable
- robust

A good team: The MINIMAT-ED handheld screwdriver, combined with the ComCenter ED, is the ideal solution for a wide range of applications. The upgraded ComCenter ED has impressive new features alongside the tried and tested characteristics of the handheld screwdriver which remain unchanged.

The powerful MINIMAT-ED is available in three versions for torques between 0.24 to 4.8 Nm at speeds of 1500 rpm. The speeds can be individually adjusted up to the maximum speed for each screwdriver type. The handheld screwdriver also benefits from a particularly slim design and is comfortably lightweight.

The MINIMAT-ED is recommended for a wide range of applications, particularly for workplaces with varying tightening parameters. There are opportunities for use in controller and control cabinet installations, in reworking stations, in series production or in repair facilities.



MINIMAT-ED Handheld Screwdriver

Advantages:

- **Flexible** – The required torque can be set directly on the screwdriver by the push of a button.
- **Economical** – Attractive purchase price and compact size due to the fully integrated controller.
- **Ergonomic**
 - End value displayed on the screwdriver
 - Trigger-start or push-to-start
 - Adjustable search run
 - Speed for each step is adjustable
 - Programming using tablet/smartphone via ComCenter ED
- **Process reliable**
 - Torque precision
 - Password protected against unauthorized changes to the preset parameter
- **Robust** – As robust as all DEPRAG MINIMAT screwdriver series: absolutely reliable and renowned for durability. The brushless drive enables high performance with low maintenance requirements.



ComCenter ED – now with new features

The ComCenter ED enables user-friendly parameterisation of screwdriving programs using the web interface. The integrated input/output port can now also be used to select MINIMAT-ED screwdriving programs. In addition, an external start release of the screwdriver is available. The main advantage: If this function is activated, the handheld screwdriver can be used in combination with other products or a higher-level PLC. This value-for-money option presents attractive opportunities. One example is combination with a position control stand (PKS). Only when the screwdriver has reached the right position is the correct screwdriving program selected and the start approval given.

Furthermore, there is the option of use in applications where sensors are used for supervision, such as in the detection of components, pick-and-place procedures or the use of a toolbox or scanner.

Your advantages:

- **flexible**
- **low cost solution**
- **for varying tightening parameters**
- **upgraded communication**



ComCenter ED – comparison of the software

Characteristics	ComCenter ED in combination with standard software OS BASIC	ComCenter ED in combination with software OS ADVANCED
Maximum number of screwdriving programs	5 tightening programs / 5 loosening programs	16
Maximum number of program steps	3	25
Tightening to torque	✓	✓
Tightening to torque with angle control	✗	✓
Tightening to angle	✓	✓
Tightening to angle with torque control	✗	✓
Loosening to angle	✓	✓
DEPRAG Friction Value Process	✗	✓
Search run / save values / waiting time	✗	✓
Statistics	✗	✓
Automatic speed reduction	✗	✓
Documentation	7 days production	7 days production
DEPRAG Operator Guidance	✗	✓
Communication interfaces	I/O interface	I/O interface and http interface
Category B (VDI/VDE 2862)	✓	✓
Category C (VDI/VDE 2862)	✓	✓

Please note: In combination with OS ADVANCED, the MINIMAT-ED screwdriver requires display version 2.0. The display can be upgraded in house at DEPRAG. Please send the MINIMAT-ED screwdriver to Amberg for the update.

SYSTEM COMPONENTS

MINIMAT-ED SCREWDRIVER Straight handle design, size 36	Type	330EG36-0012	330EG36-0018	330EG36-0032	330EG36-0048
	Part no.	440000A	440000B	440000E	440000C
Torque min.	Nm / in.lbs	0.24 / 2.1	0.36 / 3.2	0.64 / 5.66	1.0 / 8.85
Torque max.	Nm / in.lbs	1.2 / 10.6	1.8 / 15.9	3.2 / 28.3	4.8 / 42.5
Speed	rpm	1500	1500	1200	900
Diameter	mm / in.	36 / 1.4	36 / 1.4	36 / 1.4	36 / 1.4
Length	mm / in.	290 / 11.3	290 / 11.3	290 / 11.3	290 / 11.3
Weight	kg / lbs.	0.75 / 1.65	0.75 / 1.65	0.75 / 1.65	0.75 / 1.65
Noise level	dB(A)	63	63	65	65
Internal hex drive DIN ISO 1173		F6.3 (1/4")	F6.3 (1/4")	F6.3 (1/4")	F6.3 (1/4")
Suitable inserting tools and connection parts with inserting end DIN ISO 1173		E6.3 (1/4")	E6.3 (1/4")	E6.3 (1/4")	E6.3 (1/4")

Required accessories

Motor cable	length 2 m/6.6 ft.	Type	Part no.	KS4-2M	151515A
alternatives					
Motor cable	length 5 m/16.5 ft.	Type	Part no.	KS4-5M	151515B
Motor cable	length 8 m/26.4 ft.	Type	Part no.	KS4-8M	151515C
Motor cable	length 10 m/33 ft.	Type	Part no.	KS4-10M	151515D
Power unit			Part no.	NG300-ED	126422A
Power supply cable (EU)	length 2 m/6.6 ft.	Type	Part no.	KN-C13/EU	833790
alternatives					
Power supply cable (USA)	length 2 m/6.6 ft.	Type	Part no.	KN-C13/US	833791
Power supply cable (UK)	length 2 m/6.6 ft.	Type	Part no.	KN-C13/UK	833792
Power supply cable (China)	length 2.5 m/8.25 ft.	Type	Part no.	KN-C13/CN	832927
Power supply cable (Brazil)	length 1.8 m/5.94 ft.	Type	Part no.	KN-C13/BR	207388

Optional equipment

Toolbox	Type	TB 7
Technical data:	Part no.	398097B
Tool holders		7
Tool size	mm/in.	up to Ø 24/0.9 (AF 19)
Voltage	V	DC 24
Amperage	mA	100
Input/output interface		SUB-D 15 pin connector
Start signal		4-pin connector
Dimensions (W x H x D)	mm/in.	225 x 50 x 120 / 8.8 x 1.9 x 4.7
Weight	kg/lbs.	1.2 / 2.6
Connection cable ComCenter ED - Toolbox	Part no.	122840A (length 5 m/16.5 ft.)
Spring sleeve cpl.	Part no.	364672A
Spring sleeve cpl., with vacuum connection (in connection with finder, see leaflet: Inserting tools D3320E)	Part no.	364672C
Screwdriver adaption	Part no.	118246B
Connection cable ComCenter ED - PKS	Part no.	101289D
Connection cable ComCenter ED - PFC100	Part no.	952227A



Additional accessories for integration in the manual work station can be found in our brochure D3345E. For more details to the software products, please see brochure D3900E.

ComCenter ED

ComCenter ED with software OS BASIC	Part no.	103196A, including WLAN stick and connection cable to the PC
Upgrade to software OS ADVANCED activation key	Part no.	160491
ComCenter ED with software OS ADVANCED	Part no.	103196B, including WLAN stick and connection cable to the PC
Optionally available – suitable for ComCenter ED with software OS ADVANCED:		
Software DEPRAG Operator Guidance activation key	Part no.	146536
Software DEPRAG friction value process activation key	Part no.	201820

ComCenter ED with older software versions can be upgraded by ordering an update (part no. 117234).



Our software solutions undergo continuous improvements. We recommend that you regularly update your software. In this way you will always receive the most up-to-date security updates, upgraded features and drivers. With the most current version of the software you can be sure that your device is optimally prepared for Industry 4.0.

SYSTEM OVERVIEW

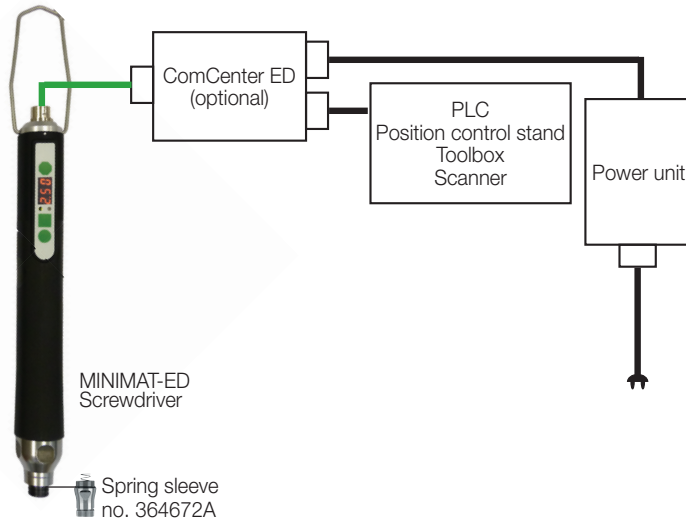

It is necessary to use a torque support (e.g. stand, handgrip) for torque: over 4 Nm for straight design and over 10 Nm for pistol grip. Suitable torque supports can be found in our brochure D3345E.

DEPRAG

DEPRAG SCHULZ GMBH u. CO.
P.O. Box 1352, D-92203 Amberg, Germany
Carl-Schulz-Platz 1, D-92224 Amberg
Phone (+49) 9621 371-0, Fax (+49) 9621 371-120
www.deprag.com
info@deprag.de

CERTIFIED AS PER DIN EN ISO 9001
