

5.400 - 15.000 Nm

MAX SPEED 3 RPM

LIGHTWEIGHT FRL UNIT (2 KG)

HIGH POWER / WEIGHT RATIO

DOUBLE SAFETY TRIGGER

OPTION

SPECIFICATIONS

- **TORQUE RANGE:** 5.400 - 15.000 Nm.
- **SPEED:** 3 RPM.
- **WEIGHT:** 19,1 Kg, excluding reaction arm and impact socket.
- **SQUARE DRIVE:** 1,5 inch square drive.
- **NOISE LEVEL:** 85 dB.
- **REPEATABILITY ON SAME JOINT*:** +/- 2%.

* -Test results from RAD's certified calibration lab

SUITABLE REACTION ARMS

Standard	Deep socket	Double ended
PN: 23776	On request	On request
Blank	Double ended blank	Safety sliding
PN: 26159	On request	On request

DIMENSIONS IN MM

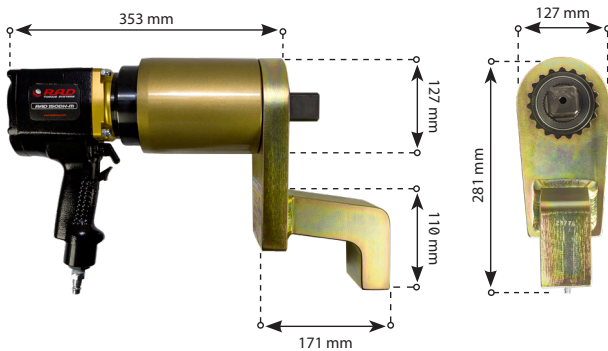

TOOL KIT INCLUDING

- 150 DX
- Standard reaction arm (PN: 23776)
- Retaining ring (PN: 18301)
- Lightweight FRL unit (2 Kg)
- 3.6 meter hose
- Airmotor oil for the FRL unit
- User manual
- Calibration certificate
- Safety instruction on USB stick



ACCESSOIRES

Product	Part number
Double safety trigger (option)	200144
Swivelling tool handle (option)	On request
Tool hanger (option)	On request
Peli cube case (option)	200317
EX certification (option)	200850

