



450 - 4.500 Nm

MAX SPEED 3 RPM

MAINTENANCE COUNTER

DIGITAL TORQUE SETTING

TORQUE + ANGLE FUNCTION

TORQUE CHECK FUNCTION

OPTION

SPECIFICATIONS

- **TORQUE RANGE:** 450 - 4.500 Nm.
 - **SPEED:** 3 RPM.
 - **WEIGHT:** 8,8 Kg, excluding reaction arm and socket.
 - **SQUARE DRIVE:** 1,5 inch square drive.
 - **NOISE LEVEL:** Maximum 80 dB.
 - **TORQUE SETTING:** 1 Nm incremental or 200 torque settings.
 - **PRESETS:** 8 programmable presets.
 - **INTELLIGENT COUNTER:** maintenance counter.
 - **REPEATABILITY ON SAME JOINT*:** +/- 3,5%.
- * Test results from RAD's certified calibration lab

SUITABLE REACTION ARMS

Standard	Deep socket	Double ended
PN: 17748	PN: 11534	PN: 11533
Blank	Double ended blank	Safety sliding
PN: 11530	PN: 11532	PN: 21377

DIMENSIONS IN MM

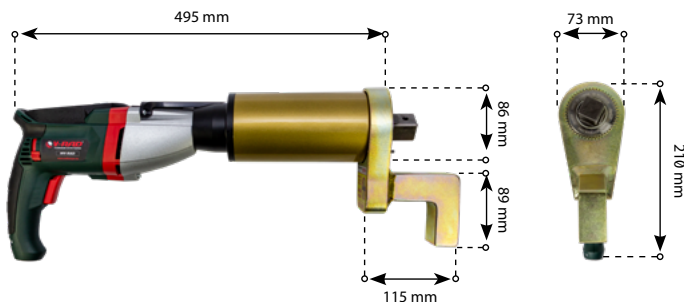

TOOL KIT INCLUDING

- MV-RAD 45
- Standard reaction arm (PN: 17748)
- Retaining ring (PN: 10032)
- Calibration certificate
- Usermanual
- Safety instructions on USB stick
- Weatherproof storage case



ACCESSOIRES

Product	Part number
Tool hanger (option)	On request
120V version (option)	17303

