



**150 - 475 Nm**

**MAX SPEED 300 RPM**

**LIGHTWEIGHT FRL UNIT (2 KG)**

**AUTOMATIC 2-SPEED**

**FAST AND LIGHT**

**DOUBLE SAFETY TRIGGER**

**OPTION**

## SPECIFICATIONS

- **TORQUE RANGE:** 150 - 475 Nm.
- **SPEED:** 300 RPM.
- **WEIGHT:** 3,7 Kg, excluding reaction arm and impact socket.
- **SQUARE DRIVE:** 3/4 inch square drive.
- **NOISE LEVEL:** 80 dB.
- **REPEATABILITY ON SAME JOINT\*:** +/- 2%.

\* -Test results from RAD's certified calibration lab

## SUITABLE REACTION ARMS

Standard

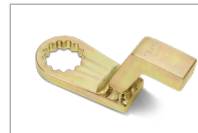

PN: 10686

Deep socket



PN: 10687

Double ended



PN: 10688

Blank



PN: 10036

Double ended blank



PN: 10037

Safety sliding



On request

## DIMENSIONS IN MM

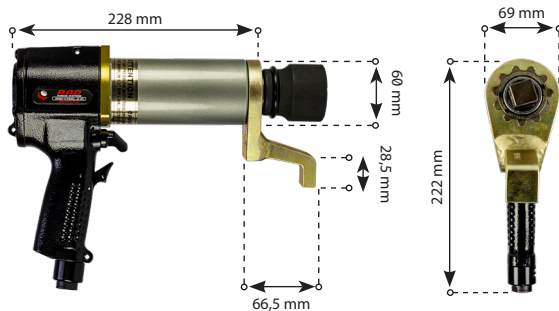

## TOOL KIT INCLUDING

- 475 SL-2
- Standard reaction arm (PN: 10686)
- Retaining ring (PN: 10306)
- Lightweight FRL unit (2 Kg)
- 3.6 meter hose
- Airmotor oil for the FRL unit
- User manual
- Calibration certificate
- Safety instruction on USB stick



## ACCESSOIRES

Product	Part number
Double safety trigger (option)	200144
Swivelling tool handle (option)	On request
Tool hanger (option)	On request
Peli cube case (option)	200317
EX certification (option)	200850

