



1.400 - 4.600 Nm

MAX SPEED 12 RPM

LIGHTWEIGHT FRL UNIT (2 KG)

HIGH POWER / WEIGHT RATIO

DOUBLE SAFETY TRIGGER

OPTION

SPECIFICATIONS

- **TORQUE RANGE:** 1.400 - 4.600 Nm.
- **SPEED:** 12 RPM.
- **WEIGHT:** 9,0 Kg, excluding reaction arm and impact socket.
- **SQUARE DRIVE:** 1 inch square drive (replaceable).
- **NOISE LEVEL:** 80 dB.
- **REPEATABILITY ON SAME JOINT*:** +/- 2%.

* -Test results from RAD's certified calibration lab

SUITABLE REACTION ARMS

Standard	Deep socket	Double ended
PN: 17748	PN: 11534	PN: 11533
Blank	Double ended blank	Safety sliding
PN: 11530	PN: 11532	PN: 21377

DIMENSIONS IN MM

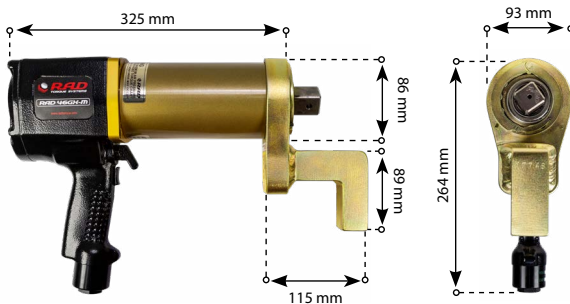

TOOL KIT INCLUDING

- 46 GX
- Standard reaction arm (PN: 17748)
- Retaining ring (PN: 11350)
- Lightweight FRL unit (2 Kg)
- 3.6 meter hose
- Airmotor oil for the FRL unit
- User manual
- Calibration certificate
- Safety instruction on USB stick



ACCESSOIRES

Product	Part number
Double safety trigger (option)	200144
Swivelling tool handle (option)	14491
Tool hanger (option)	13680
Peli cube case (option)	200317
EX certification (option)	200850

